

4-H Machine Series

Discovering Oxyacetylene Welding & Cutting

Introduction

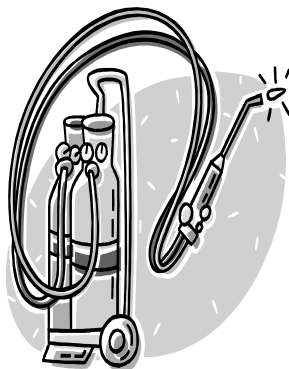

Most mechanical and industrial enterprises, as well as farm operations require the technical skills of welding and have an 'Oxyacetylene Setup' and Arc Welder' as part of their standard repair and fabrication equipment.

The greatest use for the oxyacetylene equipment is as a heating and metal cutting device. With instruction and practice it can also be used to weld and braze steel and cast iron, which can sometimes be too difficult with the arc welding process.

The equipment can be kept in the shop, or if properly secured, can be taken out to the field. It does not require any electrical power, and can be used on a variety of thickness of materials.

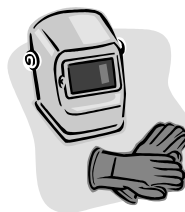

In this project you will learn about the basic equipment, operation, and safety of the oxyacetylene unit. You will also learn how to make basic weld joints and how to use the cutting torch. You will even have the opportunity to create your very own welding project!

Table of Contents	
Introduction	1
Project Summary	2
Skill Builder 1: Basic Equipment & Safety	3
Skill Builder 2: Set up, Lighting, & Shutdown	11
Skill Builder 3: Basic Weld Positions	15
Skill Builder 4: Basic Welding Joints	18
Skill Builder 5: Using the Cutting Torch	23
Skill Builder 6: Select a Project	26
Showcase Challenge	29
Portfolio Page	31

Welding on the Web

This **Welding on the Web** box will appear throughout the manual. Check out the great website link ideas. These links will lead you to fun online content to help you with your 4-H project.

- Draft 2009 -

Learning is 3D!

To help you get the most out of your learning, each activity has the following parts:

Dream it! Plan for success

Do it! Hands on learning

Dig it! What did you learn?

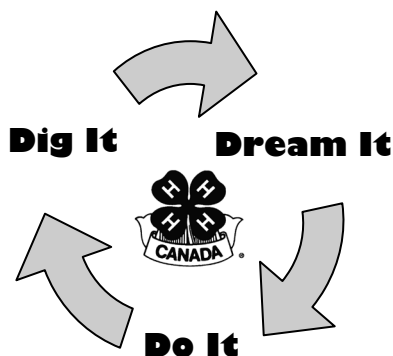

Meet Gizmo!

Gizmo is a machine that knows lots of interesting facts! Gizmo will tell you neat and important information throughout your manual.



What Skills Will You Learn?

Each section or Skill Builder (or Builder) in this project has activities that will help your project group learn to do by doing while learning new skills and having fun!



To complete this project, you must:

- Complete the activities in each Builder **OR** a similar activity that focuses on the same skills, as you and your leader may plan other activities.
- Plan and complete the Showcase Challenge.
- Complete the Portfolio Page.
- Participate in your club's Achievement (See the inside back cover for more information about 4-H Achievements).

	Members will be able to...	Activities	Page
Skill Builder 1	Basic Equipment and Safety: <ul style="list-style-type: none"> • Identify basic equipment • Understand functions of basic equipment • Understand the safety rules for working in the shop • Understand what safety equipment is required • Identify WHMIS symbols and know what they mean 	<ul style="list-style-type: none"> • Equipment Basics • WHMIS 	8 9
Skill Builder 2	Set Up, Lighting, and Shutting Down: <ul style="list-style-type: none"> • Set up an oxyacetylene unit properly and safely • Test an oxyacetylene unit for leaks • Set up a welding torch for use • Adjust the flame of a welding torch • Shut down an oxyacetylene unit properly and safely 	<ul style="list-style-type: none"> • Oxyacetylene Unit Assembly • Lighting & Shutting Down the Flame • Adjusting the Flame 	13 14 14
Skill Builder 3	Basic Weld Positions: <ul style="list-style-type: none"> • Perform forehand and backhand horizontal welds • Understand the difference between horizontal and vertical welds 	<ul style="list-style-type: none"> • Welding Word Search • Getting the Feel for the Torch • Weld Positions 	16 16 16
Skill Builder 4	Basic Welding Joints: <ul style="list-style-type: none"> • Identify and be able to weld the five basic joints - Lap, Tee, Butt, Edge, and Corner • Identify basic factors for creating a quality weld • Clean tips • Understand basic trouble shooting 	<ul style="list-style-type: none"> • Corner and Edge Joints • Butt, Lap, and Tee Joints • Creating a Quality Weld • Cleaning Tips 	21 21 21 21
Skill Builder 5	Using the Cutting Torch: <ul style="list-style-type: none"> • Set up a cutting torch • Make straight and shaped cuts 	<ul style="list-style-type: none"> • Setting up and using the Cutting Torch 	25
Skill Builder 6	Select a Project: <ul style="list-style-type: none"> • Plan and complete a project 	<ul style="list-style-type: none"> • Select a Project Or Basic Toolbox 	26 27
When you successfully complete your builders, you will showcase what you have learned.			
Showcase & Portfolio	<ul style="list-style-type: none"> • Explain success in using the skills listed above 	<ul style="list-style-type: none"> • Showcase Challenge • My Portfolio Page 	29 31



Skill Builder 1: Basic Equipment & Safety

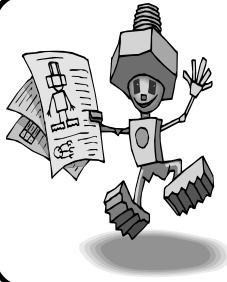

Gizmo says...

With proper instruction, a safety attitude and practice, the set up and use of oxyacetylene welding, heating, or cutting equipment can be a safe and versatile tool for farm repair and fabrication. If abused and used foolishly it can be a real danger. **Be smart and be safe!**

DISCOVER

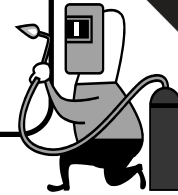

SKILLS CHECKLIST

- Identify basic equipment
- Understand functions of basic equipment
- Understand the safety rules for working in the shop
- Understand what safety equipment is required
- Identify WHMIS symbols and know what they mean

Important words

Watch for these important words throughout this builder: **Oxygen, Acetylene, Cylinder, Torch, Goggles, WHMIS**

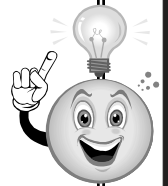

Dream it!

As a welding torch, the basic operation of an oxyacetylene unit is blending two gases, oxygen and acetylene, together in the right proportion to create a proper size flame. The flame is used to melt two pieces of metal to the point that they reach a liquid type state and flow together. This is called fusion and in most cases a filler metal rod is also heated and added to the liquid puddle. If done properly, the cooled weld can be very strong and have the same characteristics as the original part.

As a cutting torch, the operation also introduces a stream of pure “higher pressured” oxygen to the heated metal. This stream cuts (burns) a path through the metal and allows us to separate sections of base material. As a heating tool, the torch can be helpful for bending metal, getting bent parts back to where they belong, or for freeing rusted bolts.



Safety in the shop is very important. Branch off of this word web with things you can do to keep safe while welding.

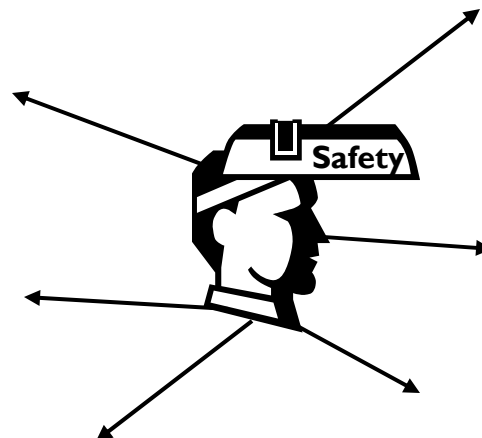

Basic Equipment

DISCOVER

Oxygen Cylinders – are tanks made of steel and come in many sizes. Cylinders are under a lot of pressure. Be careful when handling them. They have a high-pressure valve on them with a safety nut that will burst and let the oxygen out safely if the pressure in the cylinder becomes too great. Never move cylinders around without the safety cap on, unless attached to an approved oxyacetylene mobile cart. Oxygen from these cylinders is not a substitute for compressed air. This oxygen can be 99% pure and makes things burn really fast.

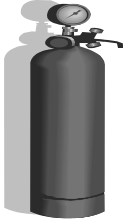

Acetylene Cylinders – These cylinders have lower amounts of pressure in them, but can be quite dangerous because acetylene is a fuel and can easily ignite. As a safety measure, acetylene should never be released or used at a rate above 15 pounds per square inch (p.s.i.). If the acetylene in the cylinder gets too hot, there are plugs on them which will melt and release the acetylene. Raw acetylene gas has a very strong odour (worse than propane) when released. It is a bad smell, but if it is leaking you know it right away.

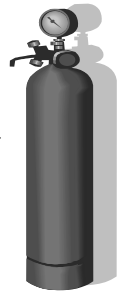

Regulators – A regulator is a device used to control pressure from the tanks by reducing pressure and regulating flow rate. Regulators for oxygen and acetylene are different. Acetylene regulators have a male fitting with a left hand thread and oxygen regulators have a female fitting with a right hand thread. Normally, both types will have two gauges on them. One will indicate the amount of pressure left in the cylinder and the other will indicate the amount of pressure that has been set by the operator to go to the torch. There is an adjusting screw in the centre of the regulator that is used to adjust the flow of gas.

Hoses – As with regulators, the fittings on oxyacetylene hoses are different than the oxygen ones. The acetylene (fuel) hose has left hand threads and the oxygen hoses have standard threads. The acetylene hoses are usually red and the oxygen hoses are green. You must be careful to keep the hoses protected from damage as they are made of a flexible rubber.

Flashback Arrestors – Not all oxyacetylene setups will have flashback arrestors or one-way check valves on them, but they are highly recommended and in some places, safety laws require them. This is to stop the travel of a spark up a hose and into a cylinder; which may result in an explosion.

Torches – The torch is the part that the welder holds and manipulates to make the weld. The most common torch for general versatility is a “combination torch”. This allows the operator to install welding tips (various sizes), heating tips (also called a rose bud), and cutting attachments to the body (handle) of the torch.

Goggles – Welding/cutting goggles should be worn at all times when welding, brazing, cutting, or when a lot of heating is required. They should have a number 4, 5, or 6 shade filter lens in them and be C.S.A. approved. They are made to protect your eyes from sparks, dust, and damaging light rays that can be produced. At all times in a shop where there are potential sparks or fragments, safety glasses with a side shield should be worn.

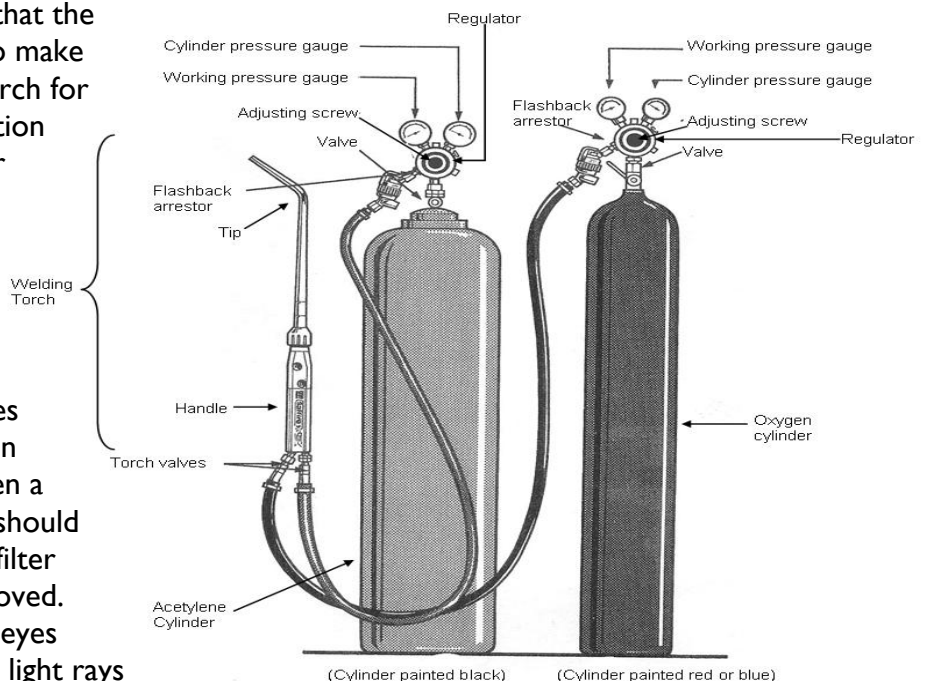

Safety

Personal safety needs to be a priority when working at any job. Accidents don't just happen. They often occur because someone was in too much of a hurry to get a job done and didn't take the proper steps or precautions to make the work safer. Welding and cutting with an oxyacetylene outfit can be safe if we respect the equipment and understand the potential danger. The following are some general considerations and rules when using the welding and cutting processes.



DISCOVER



- Dress for the job. You're going to be working with sparks and a flame that is 3500 degrees C. Proper eye protection is extremely important. A good set of coveralls, gloves, and proper foot wear can be the first line of defence against burns. Choose heavy cotton or denim clothing over nylon or fleece. Leather covered shoes or boots are better choices than running shoes.



- Never use oil. Oil, along with other petroleum base lubricants should never come in contact with oxyacetylene equipment. These products in combination with high-pressure gases can cause spontaneous combustion (explosions/fire). If cylinder valves won't open by hand or are not functioning properly, return them to the supplier. Oxyacetylene equipment is to be serviced by professionals.

- Is the area safe? The area where you are welding or cutting needs to be free of combustible or explosive materials. Sparks from a cutting torch can travel quite a distance. Welding or cutting near concrete is not a good idea as the heat can cause damage and hot materials can come popping back at you.

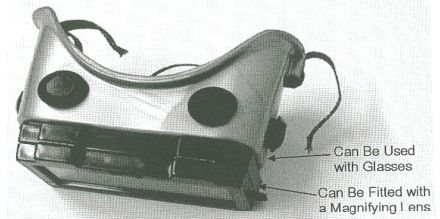

- Is there good ventilation? Welding and cutting with oxyacetylene can create harmful fumes. Welding done on galvanized metal and the brazing process are examples where zinc oxides become present. Heating, welding, or cutting on painted surfaces can cause extra smoke and fumes that are very irritating to our bodies.

- Don't weld on or cut apart containers unless you know that what was contained in them was safe. The risk of explosion or toxic fume creation is too high. Do not work on anything that has had fuel or solvents in it.
- Use a proper striker to light the torch. Using matches or lighters becomes a safety issue. Combustion can occur without a spark. Do not have both the acetylene and oxygen gases flowing when you go to light the torch.

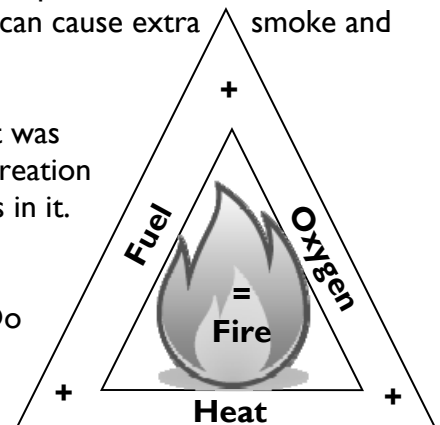

- Protect your equipment. Make sure the cylinders are secured properly. The oxyacetylene hoses are made from a durable rubber, but they can have holes melted in them or be cut open by a heavy piece of material dropping on them. Dirty or partly plugged torch tips can become inefficient and cause backfiring and an increased risk of flashback. Don't ever use the end of a cutting torch attachment to tap a piece of material that you have cut which didn't release from the base material. Be aware of where the sparks from cutting and grinding are heading. Regulators or other pieces of equipment can be damaged from them.

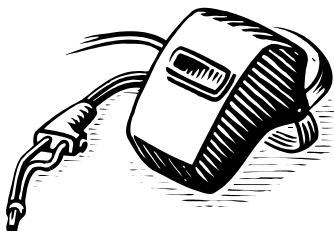

DISCOVER

- Shut the equipment down if you're going to be away from it for a while. At times, small gas leaks have occurred without notice. This is a waste of valuable gas supplies and can become dangerous. For example, if a grinder spark makes contact with a gas leak the result will be explosion and/or fire.
- Ask permission before using other shop equipment. Don't assume that everything is going to work just as you think. Get some guidance from your leader because their knowledge and past experience can help keep you safe.

WHMIS and MSDS

First things first... what does WHMIS mean and why was it created? It means **W**orkplace **H**azardous **M**aterials **I**nformation **S**ystem and was developed nationally by divisions of labour, industry, and government over a number of years to try to ensure that all hazardous materials that are produced and supplied to industry come with proper safety information. With the regulations of WHMIS legislation and the federal *Hazardous Products Act*, this information must be categorized and printed on a MSDS, which stands for **M**aterial **S**afety **D**ata **S**heet. The products must also be properly labelled with the more important information and warning symbols.



Take the time to read the following WHMIS categories and memorize their symbols.

WHMIS Hazardous Material Categories

A - COMPRESSED GAS



This category poses an explosion danger because the gas is being held in a cylinder under pressure. Handle with care; do not drop the cylinder and keep cylinders away from fire and ignition sources. *E.g. Helium, oxygen, propane, acetylene and oxygen are examples of compressed gases*

B - FLAMMABLE AND COMBUSTIBLE MATERIAL



These materials burn and are potential fire hazards. Flammable materials will catch fire at lower temperatures than combustibles, so keep them away from heat sources and other combustible materials. *E.g. Paint thinner, gasoline, methane, acetone, are examples of flammable materials.*

C - OXIDIZING MATERIAL



These pose a fire &/or explosion hazard in the presence of flammable & combustible materials. Keep oxidizers away from combustible materials such as wood and flammables such as fuels. *E.g. fertilizers, oxygen, hydrogen peroxide*



D - POISONOUS AND INFECTIOUS MATERIAL (Divided into 3 sub groups)



D1- Materials Causing Immediate and Serious Toxic Effects

These materials may be classified as toxic or very toxic. *Examples: Styrene, hydrogen cyanide, sodium cyanide*



D2 - Materials Causing Other Toxic Effects

These materials that are not immediately dangerous to health but may cause death or permanent damage as a result of repeated exposures over time (known as Other Toxic Effects). *E.g. Asbestos causes cancer, ammonia is an irritant.*



D3 - Biohazardous Infectious Material

These are Biohazardous infectious materials which may cause a serious disease resulting in illness or death such as Hepatitis B Virus. Handle all poisonous and infectious materials with extreme caution and avoid contact with the skin or eyes by wearing proper protective equipment such as gloves.



E - CORROSIVE MATERIAL

These materials cause severe eye and skin irritation or burns upon contact. Avoid inhaling and avoid skin and eye contact by wearing proper protective equipment such as gloves. *E.g. acids, Ammonia, fluorine, hydrochloric acid.*



F - DANGEROUSLY REACTIVE MATERIAL

These are materials which are extremely unstable such as sodium metal and some cyanides. They may react with water to release a toxic or flammable gas, or explode as a result of shock, friction or increases in temperature. *E.g. Ozone, hydrazine, and benzoyl peroxide are examples of dangerously reactive materials.*

Product Labeling

The following is an example of what a supplier product label looks like, and what basic information can be found on it.

Product identifier →

A risk phrase →



A hazard symbol →

Precautionary measures →

First aid measures →

Statement indicating a MSDS is available →

Supplier identifier →

TOLUENE SULPHONIC ACID 70%, LIQUID	
RISK PHRASE(S) Highly irritating to skin, eyes, and nose	
HEALTH HAZARD DATA: Strong Acid: Treat as per sulphuric acid EFFECTS OF OVEREXPOSURE, ACUTE OVEREXPOSURE: Skin and eye	
PRECAUTIONARY MEASURES SPECIFIC PERSONAL PROTECTIVE EQUIPMENT EYE: Face shield and goggles GLOVES: Rubber OTHER CLOTHING AND EQUIPMENT: Rubber apron, rubber boots	
FIRST AID MEASURES: EYES: Flush with copious quantities of water for 15 minutes. Consult physician SKIN: Flush with water as per sulphuric acid Ingestion: Treat as per sulphuric acid. Consult physician.	
REFER TO MATERIAL SAFETY DATA SHEET FOR FURTHER INFORMATION	
Henkel Canada Ltd. 162 Ward Ave. Hamilton, Ontario L8N 3M8 (416) 525-4660	

Do it!

Equipment Basics

DISCOVER

What You Need? oxyacetylene unit with welding torch, gloves, goggles/helmet

- What are all the parts of an oxyacetylene unit and what do they do?
1. Read the section of your manual on the basic equipment of a oxyacetylene unit and study the diagram labelling the various parts.
 2. After your leader has shown you the welding equipment and what each part does, try and label the parts on diagram below (without peeking at the diagram on page 4!).

Oxyacetylene Equipment

(Label the parts below)

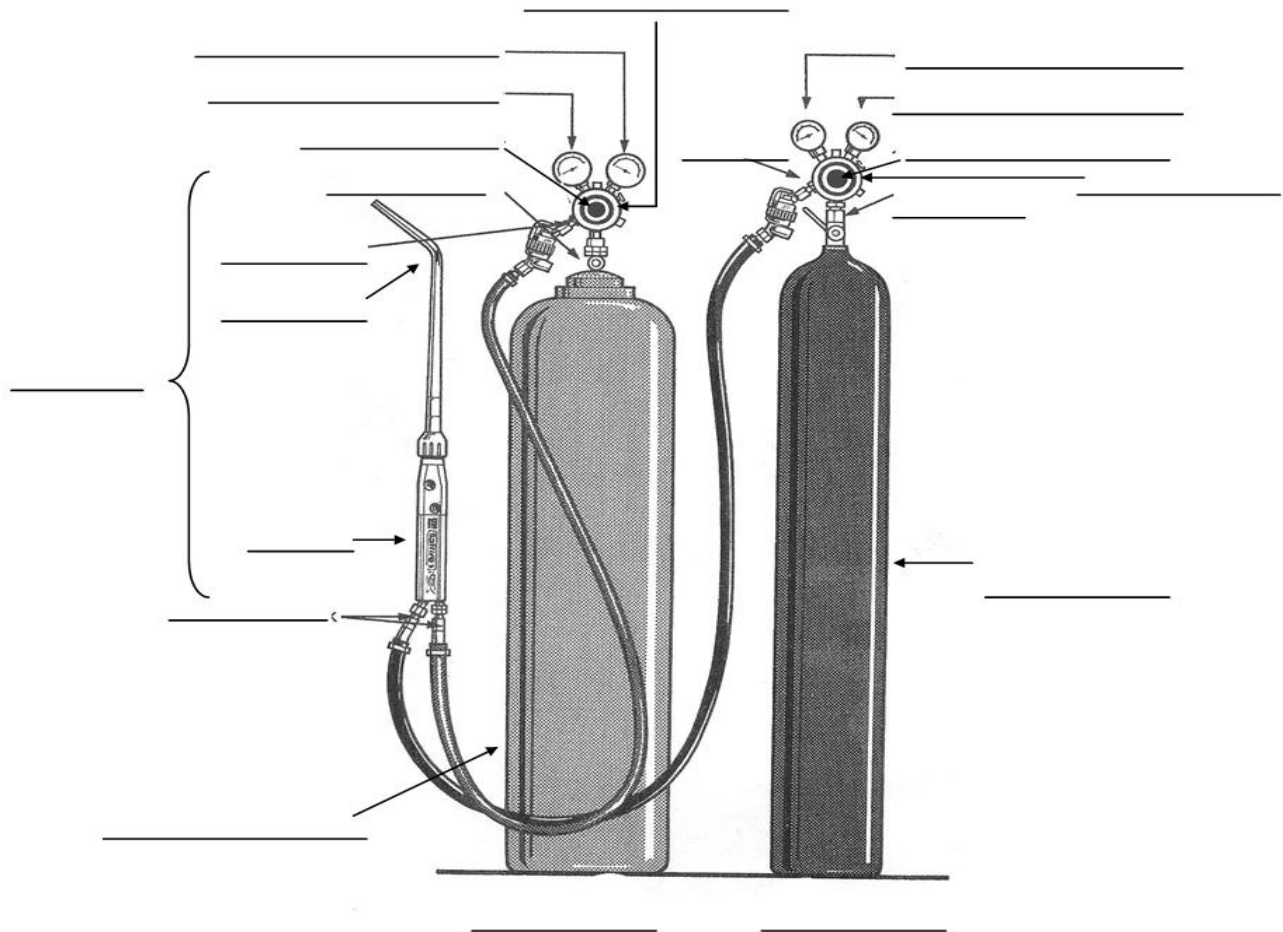

- How did you do? What strategy did you use to help remember all the parts?

Welding on the Web

Try this fun oxyacetylene equipment labeling activity on the internet at <http://www.schools.ash.org.au/dckc/tech/weld2/desew.htm>

WHMIS

- How are hazardous materials identified?

What You Need? A variety of products with WHMIS symbols, manual, pencil

DISCOVER

1. Read the WHMIS section of your manual.
2. Listen carefully as your leader shows you examples of hazardous materials with WHMIS labels
3. Label each of the WHMIS symbols below and explain what they stand for (try not to peek at the notes in your manual!)

WHMIS











Welding on the Web

Interested in a career in industrial welding? These post-secondary institutions have programs for you! To find out more information visit the school's website as listed below:

- Assiniboine Community College: www.assiniboine.net
 - Red River College: <http://www.rrc.mb.ca>
 - Winnipeg Technical College: <http://www.wtc.mb.ca>
 - University College of the North: <https://www.ucn.ca>

DISCOVER

Dig it!

Think about this builder and the activities you did ...

Review the Skills Checklist on page 3. What skills or knowledge have you acquired? Do you need more practice? Why do welding and safety go hand in hand?



Record it ...

Discuss what you have learned with your leader so that the information can be recorded on your Portfolio Page.

Apply it ...

How would you explain to others what welding safety is all about?

How Did it Go?

(Write down any thoughts, comments, questions, and what you have learned in this builder)

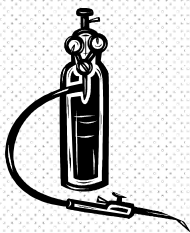

Welding on the Web

For information on the history of welding, check out this excellent website:
<http://www.weldinghistory.org/whistoryfolder/welding/index.html>

What's next?

Now that you know about the oxyacetylene unit and all the welding/shop safety rules, it is time to learn about how to properly set up, light, and shut down the unit. To get ready for the next meeting, review what you have learned so far about safety precautions and how the basic oxyacetylene equipment works.



Skill Builder 2: Set Up, Lighting, & Shutting Down

Gizmo says...

When setting up a torch system, **safety has to come first**. The cylinders must be properly secured to something stable such as a wall or if mobility is required, an approved cart. In addition, the unit must be setup and tested for leaks before ever lighting and using for welding or cutting procedures.



DISCOVER



SKILLS CHECKLIST

- Set up an oxyacetylene unit properly and safely
- Test an oxyacetylene unit for leaks
- Set up a welding torch for use
- Adjust the flame of a welding torch
- Shut down an oxyacetylene unit properly and safely

Important words

Watch for these important words throughout this builder:
Valve, Regulator, Flame



Dream it!

Setting up the oxyacetylene unit

Although a torch system does not look complicated, it must be setup and tested for leaks before ever lighting and using for welding or cutting procedures. The combination of oxygen and acetylene can produce one of the hottest flames, acetylene has always been quite popular as a fuel gas. The down side to acetylene is the ease at which it can light up, so we must ensure that there are no leaks in the system.

Safety First!

Never set up the oxyacetylene unit on your own. Make sure your leader is there to guide and supervise you.

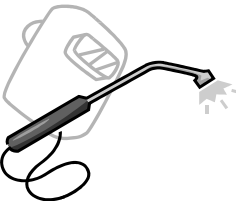

You can now install the regulators onto the cylinders by hand, screwing the fittings together and then tightening with a proper fitting wrench. Remember that fuel fittings such as acetylene or propane have left hand threads, which means you have to turn them the opposite direction to tighten.

Now attach the hoses to the regulators and tighten firmly, being careful not to over tighten and bust the fittings off the regulators. If the hoses are new or have not been hooked up to a system for some time, they should be blown out with compressed air to ensure that there is no unwanted matter in them.

Next, attach an approved set of flashback arrestors. There are two types of arrestors - one fits between the torch and hose and the other fits between the hose and the regulator. Then, the torch body can be attached and either a welding or cutting tip attached to the body. The nut that attaches the welding or cutting tip to the body should be hand tightened only.

Once the oxyacetylene outfit has been assembled, you need to set the system up for the work that is going to be performed. The following steps setup the system for torch welding and/or brazing.

DISCOVER

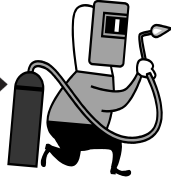

1. Check to see if the pressure adjustment screws on the two regulators has been backed off (counter-clockwise). They should feel loose. This is both a safety and a good maintenance procedure that should be practiced.
2. While standing to the side of the regulator, slowly open the acetylene cylinder valve allowing the pressure to build up on the regulator. It is recommended to open the valve from 1 to 1½ turns. The oxygen valve can be opened slowly until it is fully opened.
3. Now with the torch body in one hand, open the acetylene valve of the torch a 1/2 turn and adjust the gas flow pressure by turning in (clockwise) the adjustment screw of the regulator till the line pressure gauge indicates 4 or 5 p.s.i. and then close the torch valve. Make sure you have good ventilation as raw acetylene smells very bad and a build up of any fuel gas can be dangerous.
4. As with the acetylene cylinder, stand to the side of the oxygen regulator and slowly open the oxygen cylinder valve allowing the pressure to build up on the regulator and then continue to open the valve all the way.
5. Open the oxygen valve of the torch and adjust the oxygen regulator until there is an 8 to 10 p.s.i. flow for welding and a 25 to 35 p.s.i. flow for cutting. Close the torch valve.
6. The system should now be ready for use.



Before lighting the torch, test the system for leaks with soapy water. Using a spray bottle to apply the soapy water. Remember, you need to be wearing proper gloves and goggles and ensure that the area in which you are using the torch is safe.

Lighting the Torch and Flame Adjustment:

Have your leader guide you through the following light up, flame adjustment, and shut off procedures.

1. Being careful that the torch tip is facing a safe direction, open the torch acetylene (fuel) valve a small amount. Using a proper friction striker, light the acetylene flame and adjust it so that it is feathering at the end and there is no great amount of black (carbon) smoke being given off. Make sure you hold the striker in a way that when the acetylene ignites, the flame is not near your hand. It is possible that the striker does not ignite the acetylene the first time and a gas build up may form near the end of the tip. If you have problems getting the torch ignited, shut off the torch acetylene valve and let the area clear of raw gas.
2. Once your acetylene flame is adjusted, slowly open the torch oxygen valve and adjust the flame to form a "neutral flame". This is where there is a small bright blue cone at the end of the tip and an envelope of flame around it. Provided that the tip is clean and in good shape, this flame will not be noisy. If the flame is noisy (aggressive hiss, squeal, or screeching), you may be using too much gas flow or the torch may need to be shut down and the tip cleaned. Some regulators may "creep" a little, so the flame might have to be adjusted more than once when first starting out.

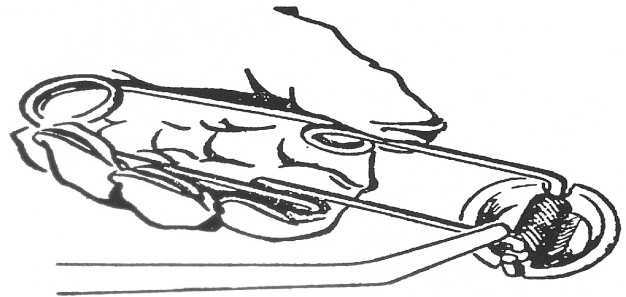

CAUTION



There are three main types of flames you can have with oxyacetylene welding: **oxidizing, neutral, and carburizing**. The ratios of oxygen to acetylene are what makes them different. Each one has a special purpose. Research one and fill in the boxes below. Compare your findings with those who picked the other types.



Shutting down the torch

Word:	Picture:	Synonym:
Sentence:		Definition:

To extinguish the flame you can simply shut off the torch acetylene (fuel) valve. This will usually result in a small pop or snap sound which is okay. **Always shut down the acetylene valve first.** Be sure to also shut the torch's oxygen valve. Oxygen does not smell, so it might not be obvious if the valve was left open a bit. The result is a waste of compressed oxygen which costs the equipment owner money to replace. It is important to maintain your tips between uses.

Shutting Down the O/A Outfit

To shut the complete system down, you can first close both cylinder valves. Next you should drain (purge) the regulators and hoses by opening the torch valves, watching the regulator gauges to ensure they are being emptied, and then closing the torch valves. Remember that the acetylene smells bad and is a fuel gas, so you need good ventilation. Once the system has been drained, back the regulator adjustment screws off so they are ready for the next time. Hang up the hoses and place the torch where it will not get damaged.

Do it!

Oxyacetylene Unit Assembly

What You Need: Disassembled oxyacetylene unit, soapy water

- What are the steps when assembling the oxyacetylene unit?
1. Review the torch set up procedure on pages 11 & 12 and the equipment diagram on page 4.
 2. Observe as your leader shows the proper unit assembly
 3. With your leader's guidance assemble the oxyacetylene unit
 4. Use soapy water to test for any gas leaks
 5. Check the appropriate box in each column

	Set up the Torch	Set up the Oxyacetylene Unit	Test for Gas Leaks
I can do this			
I need more practice			

DISCOVER

Lighting and Shutting Down the Flame

What You Need:
Oxyacetylene unit, gloves, goggles

- How do you safely light a welding torch?
1. Review the notes on lighting the torch and on safety.
 2. Observe your leader demonstrate the proper way of holding the striker and lighting and shutting down the torch
 3. Now you try. Do it a number of times to get comfortable with the procedure

Make sure you shut the acetylene valve down first and remember to shut off the oxygen valve.

Adjusting the Flame

What You Need: Oxyacetylene unit, gloves, goggles

- What are the different kinds of working flames used for?
1. Discuss everyone's findings about oxidizing, neutral, and carburizing flames.
 2. After your leader has demonstrated the different flames and explained what they are for, practice adjusting the flame so that it is neutral
 3. Correctly label each flame below.

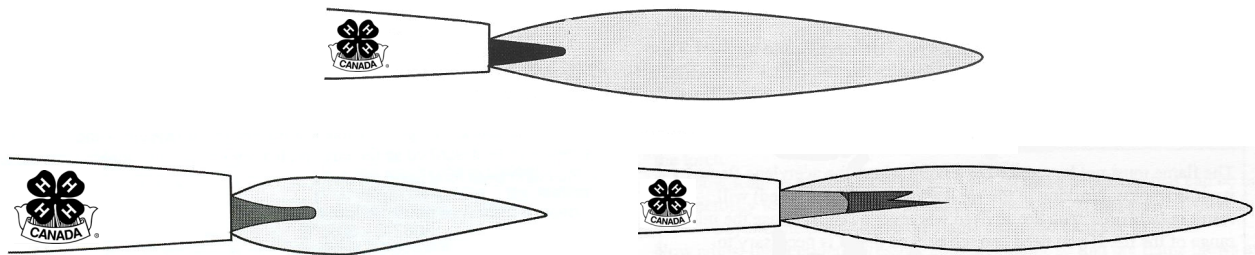

Builder Reflection

Dig it!



Why is it important to have the right kind of flame when welding?

How will your new knowledge help you in future projects?

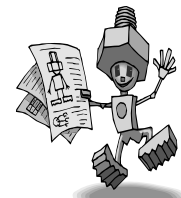

Welding on the Web

For a great additional resource on oxyacetylene welding and cutting check out:
http://www.esabna.com/EUWeb/OXY_handbook/589oxy1_1.htm

What's next?

How do you feel about operating the oxyacetylene unit? Are you ready to do some welding? In the next builder you will get comfortable handling the torch as you practice the basic weld positions.

Skill Builder 3: Basic Weld Positions

Gizmo says...

There are three basic welding positions: backhand horizontal, forehand horizontal, and vertical. The horizontal position is the easiest and most often used.



DISCOVER

SKILLS CHECKLIST



- Perform forehand and backhand horizontal welds
- Understand the difference between horizontal and vertical welds

Important words

Watch for these important words throughout this builder:

Backhand weld, Forehand weld, Horizontal weld, Puddling, Vertical weld

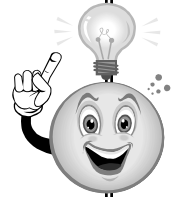

Dream it!

To begin welding, have your goggles on and your flame adjusted appropriately. When all is ready, place your welding tip approximately one inch (2.5 cm) from the steel that you are working on -this brings the flame tip in to about 1/8 - 1/4 inches away (2-4 mm). Form a weld puddle of molten metal. The torch should be held at a 45 - 60 degree angle above the metal. However, only practice will tell the welder what is the best angle for them to work at. Point the flame in the direction that you are forming the bead. Move the tip along with a slight side to side motion. This is called fusion welding and melts two pieces of steel together. Most situations require you to use filler rod to reinforce and strengthen the bond between the two pieces. When using a filler rod, place the filler rod in front of your flame dipping it into the pool of molten steel that you have made. Gradually move your way along in the direction of the bead. You can weld in either direction. It is good to learn how to do it both ways - left to right (backhand) or right to left (forehand) as different situations may arise that will only allow you to move in one direction.

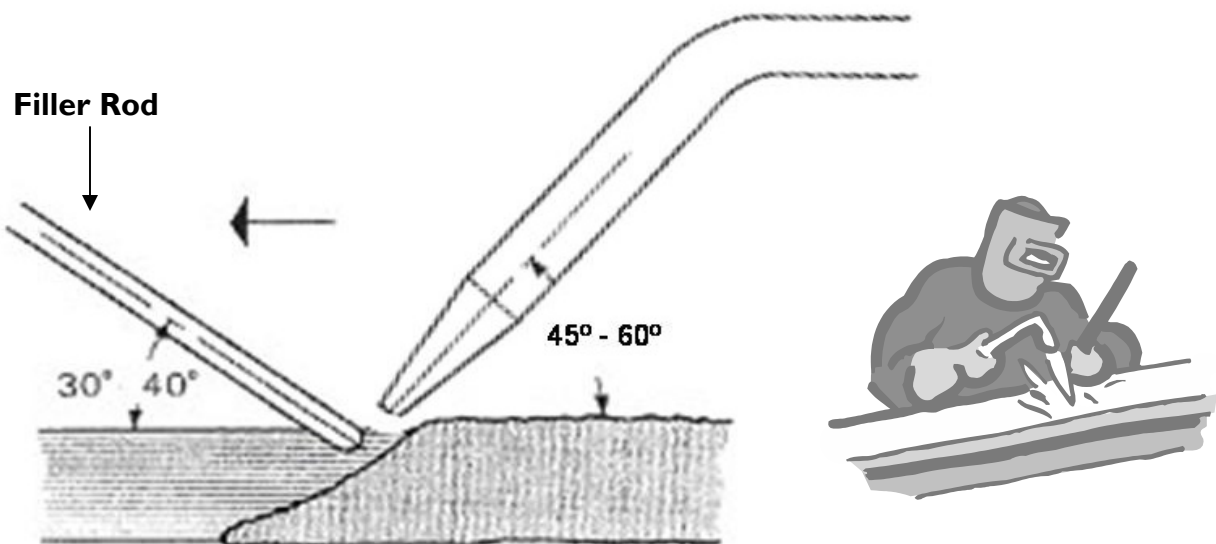

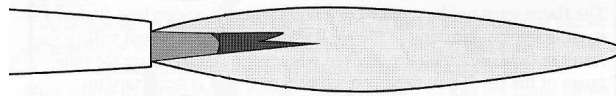

DISCOVER

Welding Word Search

Find the following words in the word search. Define and consider why each word would be included in a search about oxyacetylene welding.

P	A	H	G	O	G	L	E	S	B	D	P	K	G	
L	D	H	W	P	Y	C	U	R	A	U	U	T	E	F
E	J	N	M	N	X	M	E	Z	I	J	D	Q	P	T
C	N	T	A	B	E	D	Z	A	G	L	Y	G	U	Y
A	A	E	J	H	N	U	H	P	Z	T	N	S	D	I
R	W	X	L	I	E	C	T	P	R	I	L	D	D	A
B	U	R	L	Y	M	R	R	R	Z	R	A	N	L	F
U	C	Y	Z	N	T	D	O	I	A	E	T	A	I	L
R	C	Q	F	N	H	E	D	F	K	L	N	H	N	A
I	W	U	Q	C	S	I	C	H	O	L	O	K	G	S
Z	F	D	R	B	X	I	J	A	K	I	Z	C	H	H
I	C	O	E	O	Q	Y	M	Z	Y	F	I	A	A	B
N	T	S	L	R	X	M	A	H	F	X	R	B	T	A
G	M	A	U	V	N	R	F	N	W	U	O	Z	W	C
S	S	O	L	A	C	I	T	R	E	V	H	S	C	K

BACKHAND
CARBURIZING
CYLINDER
FILLER
FLASHBACK
FOREHAND
GOGGLES
HORIZONTAL
NEUTRAL
OXIDIZING
OXYACETYLENE
PUDDLING
TORCH
VERTICAL
WHMIS

Do it!

Getting the Feel of the Torch

What You Need: Gauge material, Oxyacetylene unit, Steel filler, Gloves, Goggles

1. Practice puddle lines on gauge material to get your hand/eye coordination and comfort levels up before welding joints. This is basic fusion welding.

Weld Positions

What You Need: Gauge material, Oxyacetylene unit, Steel filler, Gloves, Goggles

1. Observe your leader demonstrate forehand and backhand methods of horizontal welding and using the filler rod to show how to run a bead.
2. Practice the weld positions until you feel confident in doing them.

Backhand Welding

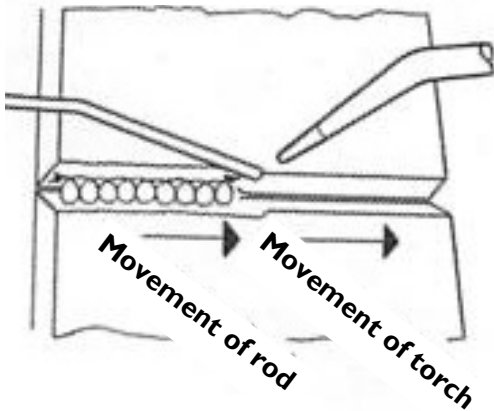

Backhand welding moves _____
to _____.



Forehand Welding

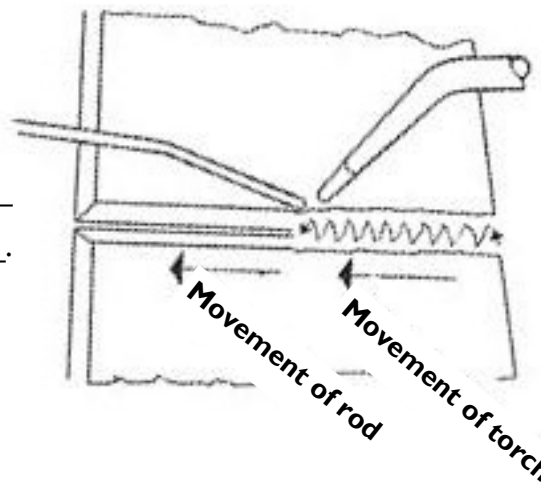

Forehand welding moves _____
to _____.

Dig it!

I am better at _____ welding.

How Did it Go?

Why should you be comfortable working with all three of the basic welding positions?

Write down any other thoughts, comments, questions, and what you have learned in this builder.



Welding on the Web

This site has a variety of videos on all kinds of welding, that you might find helpful. Use a search engine for "oxyacetylene welding video" or look at www.tonywelding.com/

What's next?

Hopefully you are now comfortable working with the three basic weld positions. In the next builder you will put the experience you have just gained to good use as you practice making the five basic welding joints.

Skill Builder 4: Basic Welding Joints

DISCOVER

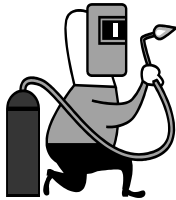

There are numerous joints and variations that you will need to weld. However, most come from five basic joints. These joints are:

- Butt joint - the most common joint with two edges butt up against each other
- Corner joint- when the two edges are at 90 degrees to each other
- Tee joint - when the edges come together - one horizontal and one vertical to make a "T"
- Edge joint- when two faces are welded together to form an edge
- Lap joint - when two faces overlap and are joined at the seam

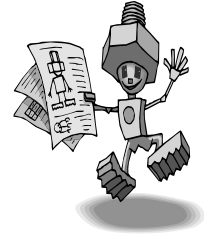

SKILLS CHECKLIST



- Identify and be able to weld the five basic joints - Lap, Tee, Butt, Edge, and Corner
- Identify basic factors for creating a quality weld
- Clean tips
- Understand basic trouble shooting

Important words

Watch for these important words throughout this builder:

Butt joint, Corner joint, Tee joint, Edge joint, Groove, Fillet, Backfire, Flashback

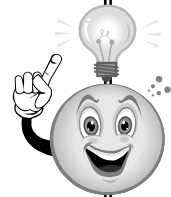

Dream it!

Basic Welding Joints

Take a look around your welding shop. Can you find an example of each of these? Write it down beside the picture.

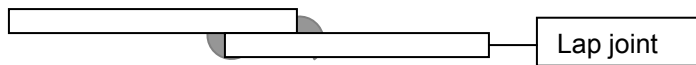

Lap joint

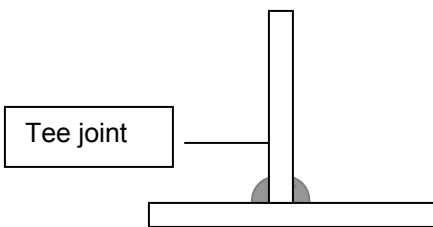

Tee joint

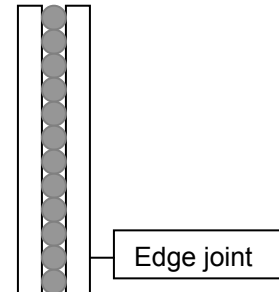

Edge joint

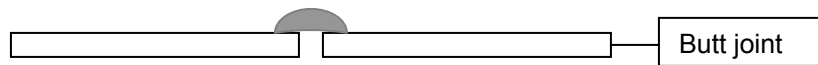

Butt joint

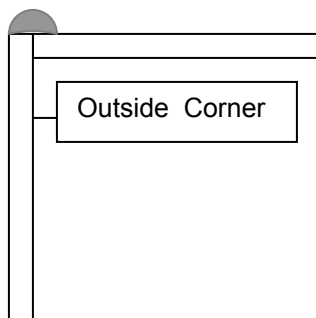

Outside Corner

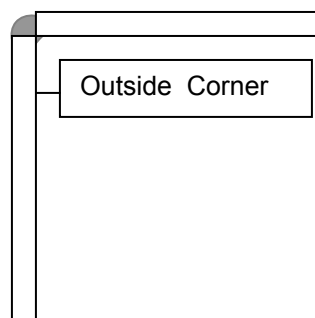

Outside Corner

Basic Weld Types

The two most common types of weld used in oxyacetylene welding are:

Groove - The groove weld is used mainly for the butt joint and can be used in the edge joint. Basically, you leave a space between your two pieces of metal that you are welding in a butt joint and fill it with a bead of weld.

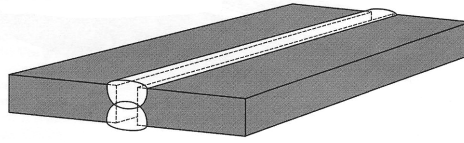

DISCOVER

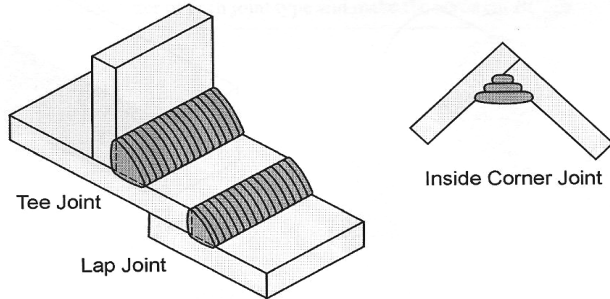

Fillet - The fillet weld is generally a layer of weld to fill in corners created in joints. The weld looks like a triangular shape. It is most commonly used on lap, tee and corner joints.

Perfecting the Weld

There are several factors that impact on the quality of your weld. These factors include:

- Tip size
- Rod size
- Flame size
- Preparation of metal
- Torch or rod angle
- Distance between torch and work
- Speed and method of torch movement
- Maintenance of equipment

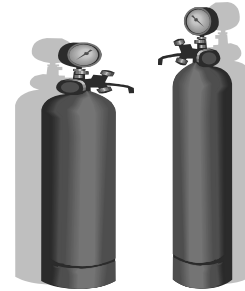

When you take all of the factors into consideration, the result is a high quality weld.

Tip and rod size: You need to select the proper tip size for the job to get the correct heat for the metal being welded. Experience and experimenting is the best teacher here. Some general guidelines include:

- Tips need to be selected to match the size of filler rod used and the thickness of the gauge metal being welded. The larger the filler rod, the thicker the metal, the higher the number of tip to be used.
- As a basic rule of thumb, choose a rod size that is the same thickness as the metal that you are welding.
- Tip sizes 3, 5 and 7 are common sizes to use for steel between 1/16"(1.6 mm) and 1/8" (3.2 mm) thick.

Flame size: If the puddle is not moving properly, it may be your tip size or it may mean you need to adjust your torch valve settings slightly. Remember that you also need to have the torch set for the correct flame type - usually neutral.

DISCOVER

Preparation of metal: Metal should be free of rust, grease, oil and paint. Use a grinder or wire brush to remove rust or paint. Anything that has had oil or grease on it should be avoided as it is potentially toxic and flammable when heated.

Torch or rod angle: The angle between the torch flame and the steel helps you to move the weld puddle where you want it. Change the angle that you are working from until you find the angle that works best.

Distance between torch and work: The closer you hold the torch to your work, the more heat is created. The greater heat increases the depth of penetration of the weld and makes the weld puddle narrower.

Speed and method of torch movement: Slower speed will make a wider weld with a deeper penetration. The object is to get a flat weld. To achieve that you may need some slight back and forth or oval motions with the torch. A steady, even speed and movement is important to achieving a quality weld.

Maintenance of equipment: If your tip becomes plugged, the flame will go sideways and splutter or go out. You need to be sure that your tips are kept clean with a tip cleaner.

The tip wears, becomes blackened, and pitted as you work with it. The tip-cleaning tool has a flat file that you can use to file the tip flat again. The cleaning tool has tip cleaners for each size of tip. Be sure to use the right size of cleaner for the tip you are cleaning as you may damage it. Be very careful when using these cleaners as they can break off inside the tip.

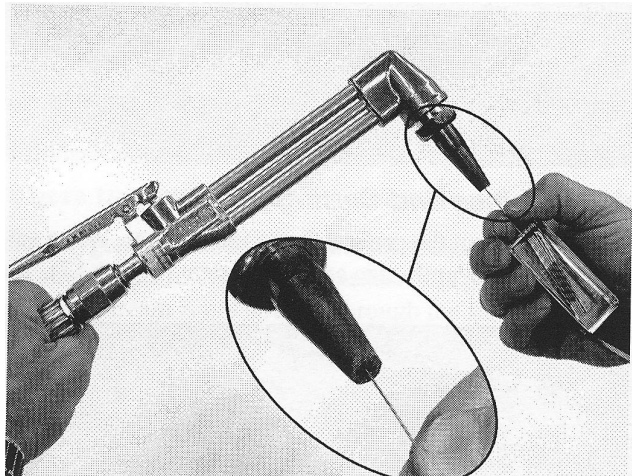
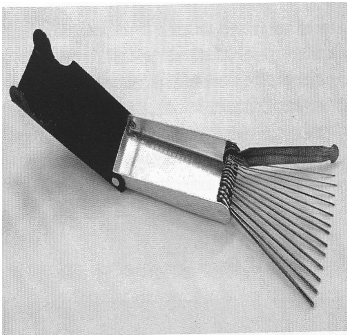

Troubleshooting Guide

Problem	Cause	Solution
Backfire: Produces a whistling noise and the torch handle gets hot	Flame is being sucked into the torch. This may be caused by: <ul style="list-style-type: none"> a spark from the metal going up the tip the tip being clogged the pressures being too low. 	<ul style="list-style-type: none"> clean the tip adjust the pressures cool down the torch
Flashback: Popping noises during operation	This is very serious and is actually a series of explosions in the gas line usually caused by: <ul style="list-style-type: none"> very unequal pressures between the two gases clogged tips 	<ul style="list-style-type: none"> be sure your equipment has flashback arrestors clean your tips adjust your pressures cool down the torch

Do it!

What You Need: Gauge material, Steel filler rod, Oxyacetylene unit, Gloves, Goggles, Tips, Tip Cleaner

DISCOVER

Corner and Edge joints

1. Take some gauge material and weld the basic design for the corner and edge joints. The corner and edge joints can be welded with or without filler.
2. Work on these joints until you are successful
3. Label and save your best samples.

Butt, Lap and Tee joints

1. Take some gauge material and weld the basic design for the butt, lap and tee joints. The butt, lap and tee joints are best welded with filler.
2. Work on these joints until you have some success.
3. Label and save your best samples.

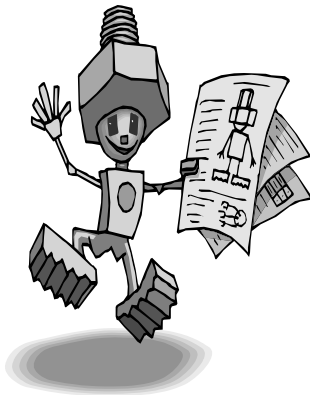

Creating a Quality Weld

1. After reviewing with your leader all the factors that contribute to a quality weld, do more practice on your joints
2. Evaluate your welds and select the best sample to share with others to demonstrate your skill in welding.

I find the _____ joint the easiest to do.

I find the _____ joint the hardest to do.

Cleaning Tips

1. Watch your leader demonstrate how to clean the tips.
2. Now practice cleaning a tip.

Welding on the Web

Want to know how welding really works?
See science.howstuffworks.com/welding.htm

Gizmo's Fast Fact

Welding is useful in several areas of the workforce. Imagine using your welding skills:

- On the farm for maintenance
- Underwater on offshore oil rigs
- In space on the International Space Station
- To create custom signs and art

The opportunities are endless! Which would you choose?

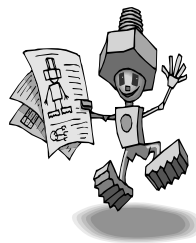

Dig it!

Picture This...

In this picture I am _____

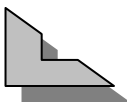

I want you to notice _____



4-H Storage box
Make sure you save your welding samples. Getting a box to store your samples in helps keep them organized and safe.

Your 4-H storage box can now include labelled samples of (check as you complete):

- | | | |
|---|---------------------|-----------------------------------|
| _____ forehand weld | _____ backhand weld | _____ lap joint |
| _____ tee joint | _____ butt joint | _____ edge joint |
| _____ corner joint | _____ quality weld | _____ guided cut (next builder) |
| _____ circle cut (optional in next builder) | | _____ freehand cut (next builder) |

What's next?

In the next builder you will get a chance at using a different kind of torch - a cutting torch. Do you think the setup, lighting, and operation of a cutting torch might be any different than the welding torch?

Skill Builder 5: Using the Cutting Torch

Gizmo says...



The cutting torch attachment is a very important and widely used tool when it comes to oxyacetylene outfits. Most farmers will tell you that the cutting attachment is almost always set up on their torch.

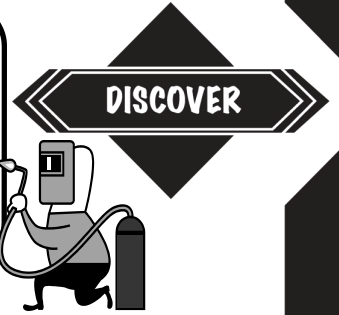

SKILLS CHECKLIST

- Set up a cutting torch
- Make straight and shaped cuts

Important words

Watch for these important words throughout this builder: **Cutting torch, “O” rings, slag**

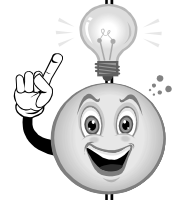

Dream it!

Begin filling this table in now and finish during Dig it! Consider things like set up, lighting, and function.

Compare (are alike)	Contrast (are different)	
Both Welding and Cutting Torch	Welding Torch Only	Cutting Torch Only

Using a Cutting Torch

The attachment can be used for both straight heating and for cutting metals of various thicknesses. The attachment works by producing a fast pre-heat system and a stream of pure oxygen. Having a number of smaller neutral flames (usually 6) around the center hole of the tip creates the pre-heat. Once these pre-heat flames have gotten the metal hot enough, the operator presses down on a lever that lets higher-pressure oxygen flow through the center hole and cut through the metal.

Setting up torch

To set up the torch for cutting, simply remove the welding tip and replace it with the cutting attachment. When installing the attachment, the nut **should be hand tightened only**. You can damage the rubber “O” rings if you over tighten by using a wrench. The rings are there to keep the gases separated and to prevent gas leaking at the joint.

The most common cutting attachment for combination oxyacetylene outfits will have an extra adjustable oxygen valve along with the oxygen release lever. This requires us to modify the way we set up and light the torch. Once the attachment is installed, the oxygen valve on the torch body can be opened all the way. This allows the full amount of line pressure to make its way to the oxygen release lever on the cutting attachment. We can light the torch the same way as before, but in order to add oxygen to the acetylene flame we have to use the adjustable oxygen valve on the cutting attachment. A neutral flame will have all of the inner flame cones at equal lengths and sizes.



Cutting Torch

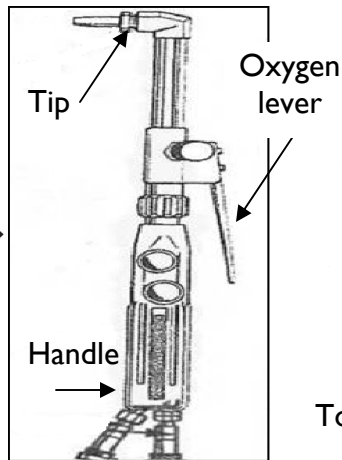

Cutting Torch Flame

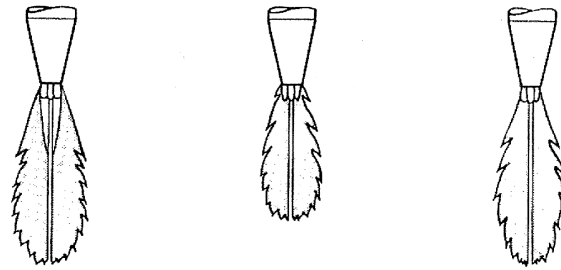

Too much acetylene Too much oxygen Correct blend

The flow pressures that we set on the oxygen and acetylene regulators will have to be changed when using the cutting attachment. For general cutting operations, a common pressure of 3- 5 p.s.i. acetylene and 25 - 35 p.s.i. oxygen will work. If the cutting tip is clean and working properly, this will allow you to cut regular steel up to 3/8 inch (10mm) thick. If the material is thicker, you may need to increase the oxygen pressure or tip size.

Producing a Clean Cut

The cutting process is not difficult but it does take a considerable amount of time and practice to become good at it. The basic process requires you to use the pre-heat flames to heat a starting area of the material you want to cut until it reaches the right temperature. Hold the flames close to the metal and wait for the material to turn bright red. This indicates that the right temperature has been reached. Once this temperature has been reached, you can press down on the oxygen release lever and then slowly move in the direction that you wish to cut. If you move too fast in that direction the cutting process will stop. You will have to let go of the lever and put the pre-heat flames back to where the process stopped and wait till you see the material turn red once again before continuing.

A common error made by beginners is getting the pre-heat flames too close to the material when cutting. If the material is hot enough and your travel speed is correct, the tips of the flames should be 1/8 inch (3mm) away from the material. You do not want to get too close as you will plug your cutting tip with slag or smother your flame.

The torch tip should be kept at a right angle to the material in most cutting situations. The angle on which you hold the cutting torch will vary according to how thick the material to be cut is and whether you are cutting in a straight line or in a shape. Selecting the correct tip size for the thickness of the material you are cutting is also important.

Another difficulty is following the line you want to cut. To help with keeping a straight line, it is a good idea to clamp a straight piece of iron down the line you want to cut (slightly offside to allow for the width of the cutting tip). This will help guide the operator as she/he cuts. When you are cutting shapes, mark the line with chalk. Then use a center punch to punch holes all along the line. This gives you a guide to follow when cutting.

Welding on the Web

Apprenticeship is post-secondary training that leads to certification as a journeyman in a skilled trade. A difference from other forms of education is as an apprentice **YOU GET PAID** to learn. Most trade programs take 2-4 years to complete and they combine approximately 80% paid-on-the-job training with 20% technical/in-school learning. Do some research on:

www.gov.mb.ca/tce/apprent/index.html

Using the Cutting Torch

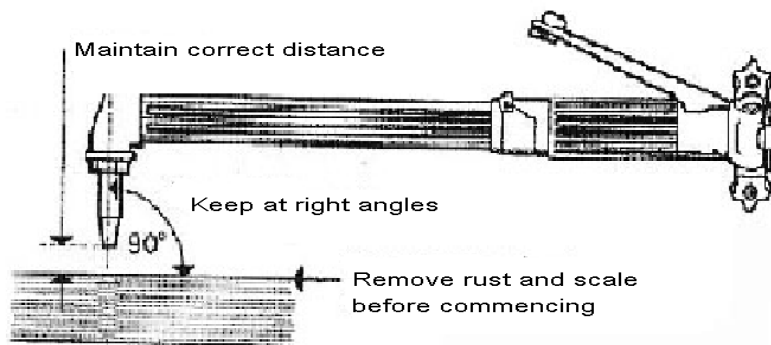

DISCOVER

As always, safety is a priority. Slag and hot pieces of metal fly when cutting. Be sure you are wearing goggles, gloves and protective gear. Make sure hot metal and slag are being deposited on metal to avoid the risk of fire or damaging shop floors.

Do it!

What You Need: Cutting torch, Gauge material, Oxyacetylene unit, Gloves, Goggles

Setting up & Using the Cutting Torch

1. With your leader's guidance, switch from a welding tip to a cutting torch attachment. Light the torch and adjust flame to neutral.
2. Adjust the oxygen regulator for a flow pressure of about 25 to 30 p.s.i. for cutting material up to 3/8 inch thick.
3. Start with cutting on a 3/16 or 1/4 inch plate using a straight edge guide.
4. After some practice try free hand cutting.
5. When you are done clean the cutting tip with the cleaning tool file and tip cleaner

Dig it!

Head back to page 23 and finish filling out the Compare/Contrast chart now that you know about the cutting torch.

How Did it Go?

Write down any thoughts, comments, questions, and what you have learned in this builder.

What's next?

You should now have a good understanding of welding and be comfortable using the oxyacetylene unit. Next up is the final builder where you will have the choice of building a tool box or coming up with and creating your own welding project idea. Think about what you would like to build and discuss it with your leader.

Skill Builder 6: Select a Project

DISCOVER

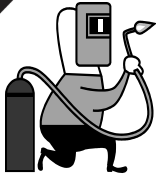

Gizmo says...
So far you have learned a lot about oxyacetylene welding and cutting. In this last builder you will now select and create a project using the skills you have acquired using oxyacetylene welding and cutting torch techniques.

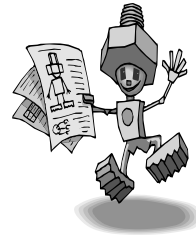

SKILLS CHECKLIST

- Plan and complete a project

Important words

Watch for these important words throughout this builder:
Blueprints, Evaluation

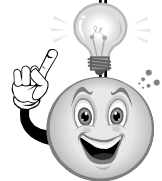

Dream it!

What are two things you could design and weld? Quickly sketch and describe them below.



You have a choice of making a basic toolbox or choosing one of your designs. If you decide to choose your own project, clear it with your leader. You will need to fill in the blueprint on the next page. If you chose to make the toolbox then follow the instructions on the next page.

What You Need:

- Possible project ideas
- Member workbook
- Oxyacetylene unit
- Cutting torch
- Welding torch
- Project supplies
- Gloves
- Goggles

Do it!

Select-a-Project

1. Develop a blue print of your project and a supplies list.
2. Record this supply list in the chart on the next page. Make sure all supplies have been gathered before the meeting.
3. With your leader's guidance build your project!
4. When your project is complete fill in the project assessment chart on the last page of this builder.

Blueprint for:

Supply List

Instructions

DISCOVER

Diagrams

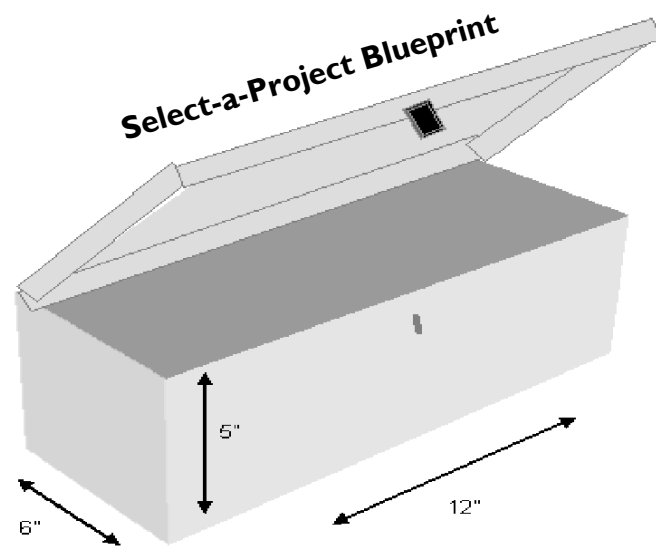

What You Need:

- 2 pieces of 18" x 6" x 1/16" (45 cm x 15 cm x 1.6 mm) flat plate (sides)
- 1 piece of 12" x 6" x 1/16" (30 cm x 15 cm x 1.6 mm) flat plate (bottom)
- 1 piece of 12 1/4" x 6 1/4" x 1/16" (30.5 cm x 15.5cm x 1.6 mm) flat plate (lid)
- 1 piece of 1" x 24 3/4" x 1/16" (2.5 cm x 61.5 cm x 1.6 mm) (lid surround)
- 1 metal gate handle (or make your own handle)
- 1 -12" heavy duty piano hinge or 2 door hinges
- 1 clasp

Basic Toolbox

1. Bend the first 2 -18" (45 cm) pieces at 6" (15 cm) to right angle.
2. Weld the 2 corner seams of the sides together to form a rectangular box.
3. Weld the 12" x 6" piece (30 cm x 15 cm) on to the bottom.
4. Bend the lid surround - the 1" x 24 3/4" (2.5 cm x 61.5 cm) piece to form three sides. Bends need to be at right angles at 6 1/4" (15.5 cm)
5. Weld the surround to the lid plate - the 12 1/4" x 6 1/4" (30.5 cm x 15.5cm) piece.
6. Weld the hinge(s) on the back side for smooth movement of the lid.
7. Weld on the handle and clasp.
8. Spray paint your toolbox with metal rust paint if you'd like.
9. Fill in the project assessment chart on the following page.

Dig it!

Project Evaluation



	Yes	No
Did you use the correct material for your project?		
Are your welds of the appropriate strength?		
Is your welding uniform and smoothly rounded?		
Is your product ready to use?		

What about your project are you most proud of?

What skills do you feel you have learned?

What would you do differently if you had to make it over again?



Picture This...

In this picture I am _____

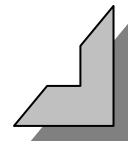
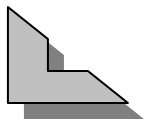

I want you to notice _____

What's Next?

Next is the Showcase Challenge! This is an opportunity to bring together and share what you have learned.

Showcase Challenge

Bringing it all together!

DISCOVER

Now that you have finished this project, it is time to think about how you will share your experiences and knowledge with others. You may put your new skills to work by helping at a community event or at your club Achievement or teaching others about your topic. The goal of the Showcase Challenge is to help highlight your new skills and help **you** understand how you can use them. It can be an opportunity to receive feedback from others on your project. So go back through your manual and find some highlights of your learning (what you are proud of) and think about how you will “showcase” it.

Dream It!

Here are some Showcase Challenge Suggestions:

- Demonstrate something you made or learned about
- Make a poster or display
- Make a pamphlet
- Make a computer presentation (e.g. PowerPoint)
- Give a speech
- Write a report
- Use your new skills to help with the Club Achievement plans
- Or come up with your own idea. It is up to you and your leader!



My Showcase Challenge Plan



My showcase idea: _____

What materials and resources do I need? _____

Who do I need to help me? _____

When do I need to have things done by? _____

DISCOVER

Do It!

Insert or attach your finished product or a photo of you sharing your skills in your Showcase Challenge.



Dig It!

Now that you have showcased your project skills;

- How did your Showcase Challenge go?
- What would you do differently next time?
- How will you use your new skills in the future? (*in different situations?*)





My 4-H Portfolio Page **Manitoba**

Name: _____ Date: _____ Year in 4-H: _____

Club: _____ Hours Spent on 4-H: _____ (Project and Other 4-H Activities)



Discovering Oxyacetylene Welding & Cutting Skills Chart

To be completed by the leader and the member based on observations and conversations throughout the project.

Skill Builder	Members will be able to...	We know this because...
1	<ul style="list-style-type: none"> Identify basic equipment Understand functions of basic equipment Understand the safety rules for working in the shop Understand what safety equipment is required Identify WHMIS symbols and know what they mean 	
2	<ul style="list-style-type: none"> Set up an oxyacetylene unit properly and safely Test an oxyacetylene unit for leaks Set up a welding torch for use Adjust the flame of a welding torch Shut down an oxyacetylene unit properly and safely 	
3	<ul style="list-style-type: none"> Perform forehand and backhand horizontal welds Understand the difference between horizontal and vertical welds 	
4	<ul style="list-style-type: none"> Identify and be able to weld the five basic joints Identify basic factors for creating a quality weld Clean tips Understand basic trouble shooting 	
5	<ul style="list-style-type: none"> Set up a cutting torch Make straight and shaped cuts 	
6	<ul style="list-style-type: none"> Plan and complete a project 	

Additional Comments/Activities:

Leader Point of Praise!

I am most impressed by...

I acknowledge that the member has completed the 4-H project requirements.

Leader's Signature: _____



Above and Beyond!

In addition to project skills, 4-H also increases skills in meeting management, communications, leadership, community involvement through participation in club, area, or provincial 4-H events or activities. List below any activities you participated in this year in 4-H.

(Some examples include Executive Positions Held, Workshops, Communication, Community Service, Rally, Bonspiels, Conferences, Judging, Camps, Trips, Awards, Representation to Area or Provincial Councils, etc)

**Feel Free to add additional pages that include awards, certificates, new clippings, photos or other items that describe your 4-H involvement.

Member Point of Pride!

What I learned...

What I need to improve on...

What I want others to notice...

Member's Signature: _____



Point of Praise! Another's perspective on your achievements in 4-H.

(community professionals, MAFRI staff, 4-H club head leaders, 4-H Ambassadors, friends of 4-H)

I am most impressed by...

I believe that you have learned...

In the future I encourage you to...

Signature: _____





4-H Achievement

4-H Achievement is... a 4-H club celebration when members have completed their projects. Achievements are planned by the club to give recognition to members and leaders for their accomplishments in their 4-H projects and club activities.



A 4-H Achievement can take many different formats: from choosing a theme, to member project displays, to members using their new skills for the event (entertainment, food, decorating, photographer, etc.), to members presenting their project to the whole group, the options are endless and open to the creativity of the members and leaders in each club!

Clubs may also plan their Achievement to promote 4-H to the community or to recognize sponsors and others who have helped the club.

Members and leaders - be sure to check your project books for the project completion requirements, so you will be ready for your club's Achievement celebration!

If you have any questions, comments or suggestions for this or other 4-H projects contact:

**Manitoba 4-H Projects
Manitoba Agriculture Food and Rural Initiatives
1129 Queens Avenue
Brandon, MB R7A 1L9**

Email: 4h@gov.mb.ca

Phone: 204-726-6613

Fax: 204-726-6260

This manual is for educational use only and is not intended as professional advice.



For more information about 4-H and the many 4-H opportunities available please visit

<http://www.gov.mb.ca/agriculture/4-h/>



DISCOVER

What is 4-H?

4-H is an international youth organization involving more than 7 million members in 80 countries around the world.

In Canada, 4-H began in 1913 in Roland, Manitoba as a community-based organization dedicated to growth and development of rural youth. Today's 4-H program reaches both farm and non-farm youth across Canada. The motto of "Learn to Do by Doing" is embodied in the program, as 4-H focuses on skill development as well as personal development of life skills such as communications, leadership and citizenship.



4-H Motto

"Learn To Do by Doing"

4-H Pledge

I pledge,
My HEAD to clearer thinking,
My HEART to greater loyalty,
My HANDS to greater service,
My HEALTH to better living,
For my club, my community, and my country.

4-H Quality Equation Principles

Quality People

- Promote responsibility, respect, trust, honesty, fairness, sportsmanship, citizenship, teamwork and caring.

Quality Experiences

- Provide members with personal development and skill development experiences.

Quality Projects

- Promote and value quality effort.
- Promote high quality, safe food production within industry standards.



Manitoba 4-H project material is developed by
Manitoba Agriculture, Food and Rural Initiatives (MAFRI)

